

Tapered Rollers 42R9

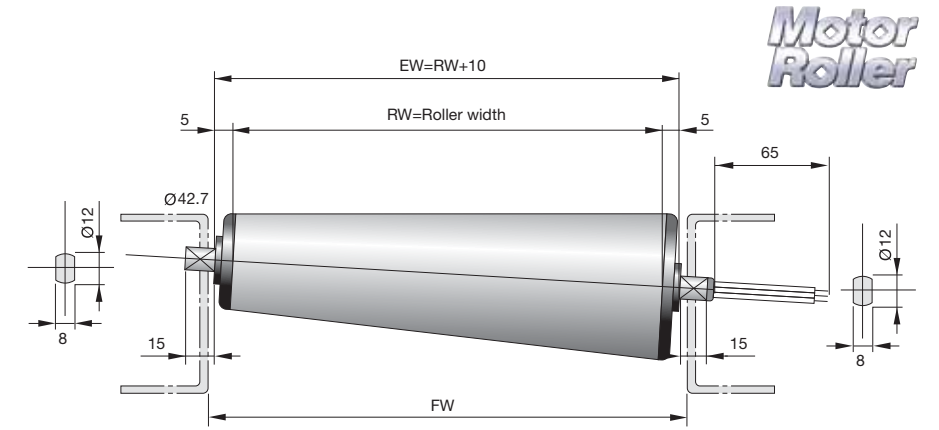

Tapered roller dimensions/weight

RW=Roller width (FW-12)	300	400	500	600	700	800
Width inside the frame (FW)	312	412	512	612	712	812
Weight (kg)	2.4	2.6	3.0	3.3	3.7	4.4
Snap-on shaft	○	○	○	○	○	○



50Hz

42R9SC J-C J-3-200/220

Roller width Small dia. 42.7mm R=900	300 (large dia. 57mm center dia. 50mm)		400 (large dia. 60mm center dia. 52mm)		500 (large dia. 65mm center dia. 54mm)	
	Speed (m/min.)	Tangential force (N)	Speed (m/min.)	Tangential force (N)	Speed (m/min.)	Tangential force (N)
42R9S 4-[]-3-[]	3.5	93.9	3.7	90.3	3.8	87.0
42R9S 6-[]-3-[]	5.9	64.1	6.1	61.6	6.3	59.3
42R9S 8-[]-3-[]	7.6	47.0	7.9	45.2	8.2	43.5
42R9S10-[]-3-[]	10.5	25.6	11.0	24.6	11.4	23.7
42R9S13-[]-3-[]	—	—	—	—	—	—
42R9S15-[]-3-[]	16.4	21.4	17.0	20.5	17.7	19.8
42R9S20-[]-3-[]	21.1	17.1	21.9	16.4	22.8	15.8
42R9S25-[]-3-[]	25.8	12.0	26.8	11.5	27.8	11.1
42R9S30-[]-3-[]	30.4	8.5	31.7	8.2	32.9	7.9
42R9S35-[]-3-[]	—	—	—	—	—	—
42R9S45-[]-3-[]	—	—	—	—	—	—

motor 42S motor is used. Refer to the relevant page for electric characteristics.
The figures in the above table show data obtained on the basis of roller center diameter and three-phase 220 V motor.
Suitable for conveyance of light load (30 kg or less)

42R9SC J-C J-3-200/220/380/415 800mm for stainless cannot be manufactured

600 (large dia. 70mm center dia. 57mm)		700 (large dia. 75mm center dia. 59mm)		800 (large dia. 75mm center dia. 61mm)		Roller width Small dia. 42.7mm R=900
Speed (m/min.)	Tangential force (N)	Speed (m/min.)	Tangential force (N)	Speed (m/min.)	Tangential force (N)	
4.5	150.0	4.7	144.9	4.8	140.2	42R9S 4-[]-3-[]
6.5	110.0	6.7	106.3	7.0	102.8	42R9S 6-[]-3-[]
8.5	85.0	8.8	82.1	9.1	79.4	42R9S 8-[]-3-[]
10.5	65.0	10.9	62.8	11.2	60.7	42R9S10-[]-3-[]
14.5	54.0	15.0	52.0	15.5	51.0	42R9S13-[]-3-[]
17.5	45.0	18.1	43.5	18.7	42.0	42R9S15-[]-3-[]
21.0	33.0	21.7	31.9	22.5	30.8	42R9S20-[]-3-[]
26.0	27.0	26.9	26.1	27.8	25.2	42R9S25-[]-3-[]
32.0	22.0	33.1	21.3	34.2	20.6	42R9S30-[]-3-[]
35.0	19.0	36.2	18.4	37.5	17.8	42R9S35-[]-3-[]
45.0	14.0	46.6	13.5	48.2	13.1	42R9S45-[]-3-[]

motor 57S motor is used for the roller width of 600 mm or more.
Refer to the relevant page for electric characteristics.
The figures in the above table show data obtained on the basis of roller center diameter and three-phase 220 V motor.

Please contact us for the accumulator type.

50Hz

60Hz

42R9SC J-C J-3-200/220

Roller width Small dia. 42.7mm R=900	300 (large dia. 57mm center dia. 50mm)		400 (large dia. 60mm center dia. 52mm)		500 (large dia. 65mm center dia. 54mm)	
	Speed (m/min.)	Tangential force (N)	Speed (m/min.)	Tangential force (N)	Speed (m/min.)	Tangential force (N)
42R9S 4-[]-3-[]	4.1	76.9	4.3	73.9	4.4	71.2
42R9S 6-[]-3-[]	6.4	47.0	6.7	45.2	7.0	43.5
42R9S 8-[]-3-[]	8.8	38.4	9.1	37.0	9.5	35.6
42R9S10-[]-3-[]	12.9	21.4	13.4	20.5	13.9	19.8
42R9S13-[]-3-[]	—	—	—	—	—	—
42R9S15-[]-3-[]	19.3	17.1	20.4	16.4	20.9	15.8
42R9S20-[]-3-[]	24.6	12.8	25.6	12.3	26.6	11.9
42R9S25-[]-3-[]	30.4	8.5	31.7	8.2	32.9	7.9
42R9S30-[]-3-[]	35.1	6.8	36.5	6.6	37.9	6.3
42R9S35-[]-3-[]	—	—	—	—	—	—
42R9S45-[]-3-[]	—	—	—	—	—	—

motor 42S motor is used. Refer to the relevant page for electric characteristics.
The figures in the above table show data obtained on the basis of roller center diameter and three-phase 220 V motor.
Suitable for conveyance of light load (30 kg or less)

42R9SC J-C J-3-200/220/380/480 800mm for stainless cannot be manufactured

600 (large dia. 70mm center dia. 57mm)		700 (large dia. 75mm center dia. 59mm)		800 (large dia. 75mm center dia. 61mm)		Roller width Small dia. 42.7mm R=900
Speed (m/min.)	Tangential force (N)	Speed (m/min.)	Tangential force (N)	Speed (m/min.)	Tangential force (N)	
5.0	130.0	5.2	125.6	5.4	121.5	42R9S 4-[]-3-[]
7.5	90.0	7.8	86.9	8.0	84.1	42R9S 6-[]-3-[]
10.0	85.0	10.4	62.8	10.7	60.7	42R9S 8-[]-3-[]
12.0	47.0	12.4	45.4	12.8	43.9	42R9S10-[]-3-[]
17.5	39.0	18.1	38.0	18.7	37.0	42R9S13-[]-3-[]
20.0	34.0	20.7	32.8	21.4	31.8	42R9S15-[]-3-[]
24.0	26.0	24.8	25.1	25.7	24.3	42R9S20-[]-3-[]
30.0	20.0	31.1	19.3	32.1	18.7	42R9S25-[]-3-[]
36.0	16.0	37.3	15.5	38.5	15.0	42R9S30-[]-3-[]
42.0	14.0	43.5	13.5	44.9	13.1	42R9S35-[]-3-[]
54.0	11.0	55.9	10.6	57.8	10.3	42R9S45-[]-3-[]

motor 57S motor is used for the roller width of 600 mm or more.
Refer to the relevant page for electric characteristics.
The figures in the above table show data obtained on the basis of roller center diameter and three-phase 220 V motor.

Please contact us for the accumulator type.

60Hz